

UNITEC Instruction Manual

Air Drill

2-1903-0010, 2-1924-0010, 2-1932-0010

This Instruction Manual was written to provide the user with information about the safe operation and maintenance of C.S UNITEC air drills. Read this manual thoroughly and become completely familiar with your air drill before using it.

Table of Contents

- ◆ Safety alert symbols used in this manual.....1
- ◆ Safety Precautions to be taken when using air drills.....2
- ◆ When installing or changing drills or tappers.....2
- ◆ Pictorial nomenclature.....3
- ◆ Instructions for use.....3
- ◆ Specifications.....4
- ◆ Maintenance and inspection.....4
- ◆ Repair.....4
- ◆ C.S UNITEC Offices.....4

◆ Safety alert symbols used in this manual◆

This instruction manual uses the following safety alert symbols. When you see those symbols in the text, follow the safety message to avoid personal injury or death.



WARNING: Failure to follow the instructions in the message might cause a serious accident or death.



CAUTION: Failure to follow the instructions in the message may cause personal injury or damage to the air tool.

WARNING

Read this manual thoroughly and become completely familiar with the air drill before using it. We don't take responsibility for an accident or malfunction caused by misuse or improper operation.

Keep this manual as a ready reference for anyone who may use the air drill.

If this instructions manual is missing or any warning missing or defaced (damaged or illegible), replace with a new one. The instructions manual and label are available through your local C.S UNITEC dealer.

If the air drill is to be leased, loaned, or sold to anyone, this manual must be with the air drill.

If you have any question about the products or the description in this manual, contact us or your local C.S UNITEC dealer.

Safety precautions to be taken when using air drills - BEFORE USE

WARNING

The air drill is an air tool designed for drilling holes with a drill. Do not use the air drill for purposes other than specified; otherwise an accident may result.

It is recommended to install a filter, a pressure reducing valve and an oiler at the air inlet port.

Do not use an air pressure of higher than 0.6 MPa. Otherwise, the internal parts or chuck may be damaged, causing an accident.

Use accessories in a proper manner. If you have any question about how to use them, contact their respective manufacturers or dealers. Misuse of accessories can cause an accident.

Before starting operation, remove all tools used for installation of a tool from the air drill. Tools may fly off and cause injury.

Safety precautions to be taken when using air drills - DURING USE

WARNING

Lock the work securely. Otherwise, the work might fly, causing a serious accident.

Hold the air drill firmly and prepare for reaction force. Reaction force changes abruptly when the drill penetrates through the work. Avoid operating a large air tool alone; otherwise, its reaction torque may whack you.

Do not make jerky starts of the air drill. There is danger of causing an accident or malfunction of the machine. Operate the starting switch slowly.

WARNING

Wear protective glasses. Use any other appropriate protective gear such as ear plugs and protective shoes.

Check the rotating direction of the direction lever before starting the air drill. If the air drill rotates in the direction you don't expect, you might get injured. Make sure to stop the air drill before switching over the rotating directions.

Use caution not to get burned. The head tool such as a drill is very hot immediately after use. Do not touch it inadvertently.

Securely tighten the air hose connection if any looseness is found during operation. If the air hose comes off during operation, it will jump, and may cause an accident.

CAUTION

When the air drill is not provided with an oiler, add approximately 0.5 ml of turbine oil (ISO VG32 or equivalent) through the air supply port, before and after operation. Then allow the air drill to run without load for 2 to 3 seconds, with care not to allow dirt or dust into the system. Unlubricated operation may cause the air drill to fail to operate normally, thus resulting in an accident.

When the air drill is provided with an oiler, add turbine oil (ISO VG32 or equivalent) and adjust the drip rate of oil to a few drips per minute. Unlubricated operation may cause the air drill to fail to operate normally, thus resulting in an accident.

Before starting each shift, drain the tank or air filter. Air containing a lot of water will cause the malfunction of the air drill or result in an accident.

Use caution not to allow the entrance of dirt into the unit when connecting the air hose. Failure to protect the unit against the entrance of foreign matter may cause the malfunction of the air drill or an accident. Before connecting the air hose to the air drill, idle the machine until no dirt or water comes out of it, and wipe away any dirt or dust from the air hose connection area.

Safety precautions to be taken when using air drills - WHEN INSTALLING OR CHANGING DRILLS

WARNING

Remove the air hose before removal and installation of a tool such as a drill.

If the air drill starts rotating unintentionally, it may cause an accident. When any protective device (such as coupler) is not equipped which automatically shuts off the air, close the main cock, operate the machine once to discharge the air remaining inside the air hose before removing it. Otherwise, the air hose can jump about due to the remaining air pressure when disconnected.

◆ **Safety precautions to be taken when using air drills - WHEN INSTALLING OR CHANGING DRILLS - CON'T**

⚠ **WARNING**

Use the proper head tool (drill chuck, drill socket, or drill) that meets the requirements (dimensions) of your air tool.

Use of any improperly sized head tool may result in an accident.

Install the head tool such as a drill securely.

Poor installation of the head tool such as a drill may cause an accident, malfunction of the air drill or premature service life of the socket.

When installing the drill to a large air tool (see the figure below), loosen the feed handle by turning counterclockwise approximately 10mm from its fully clockwise (tightened) position. A drill comes off when the feed handle is turned (tightened) fully clockwise.

Please make sure to remove oil or dust on taper part both of unit and drill chuck when you install drill chuck (or drill) into the body.

If not, it will be at risk of coming off.

◆ **Pictorial Nomenclature**

2-1903-00010

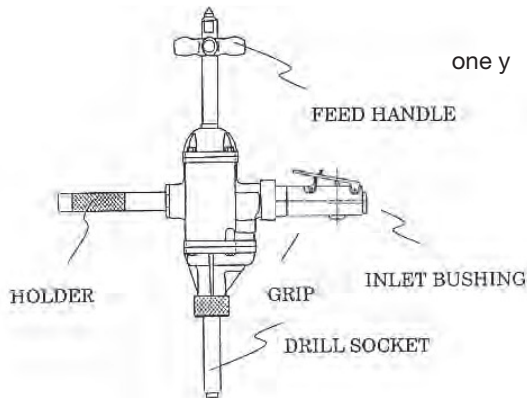

2-1924-0010, 2-1932-0010

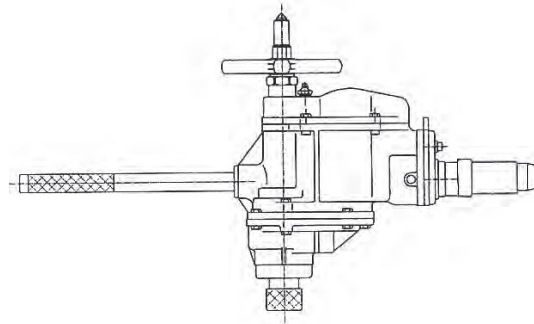

◆ **Instructions For Use**

FOR SMALL AIR TOOLS :

- 1.) Hold the tool with both hands.
- 2.) Press the tip of the drill vertically against the place where a hole is to be drilled.
- 3.) Push the lever slowly to rotate the drill. When the lever is released, the drill will stop

FOR LARGE AIR TOOLS:

- 1.) Normally hold the air tool by two persons - one holding the holder; the other the grip. Reaction torque may whack you if the air tool is held by yourself. Use of an auxiliary tool as shown on the next page allows for safer and easier operation.
- 2.) Press the tip of the drill vertically against the place where a hole is to be drilled.
- 3.) Grip Type - Turn the grip slowly counterclockwise (R position) to rotate the drill clockwise. The the grip is returned to the neutral position (zero position), the drill will stop rotating. When the grip is turned clockwise (L position), the drill will rotate counterclockwise.

Example of auxiliary tool for use with a large air tool

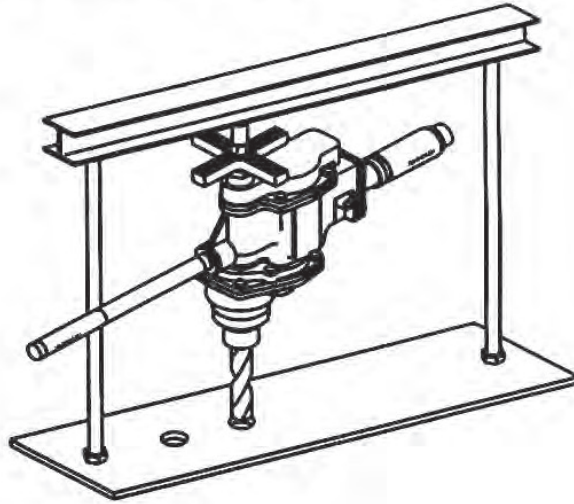

Morse taper shank type (Large air tool)

Type	(Wood) Capacity (Drill Diameter)	Chuck Style	Max. Free Speed	Overall Height	Weight	Shank Center to Side Distance	Feed Length	Hose Inlet Thread	Hose Size	Air Cons.
	IN		r.p.m	IN	LBS	IN	IN	NPT	IN	CFM
2-1903-0010	1"	1/2" Wood	750	17 1/2"	14 1/2	1 1/2	2 1/4	3/8	1	39
2-1924-0010	2"	1/2" Wood	700	18 1/2"	24 3/4	1 3/4	4	1/2	1	50
2-1932-0010	3"	1/2" Wood	380	18 1/2"	14 1/2	1 1/2	2 1/4	3/8	1	50

◆ Maintenance and Inspection

⚠ WARNING

Make sure to perform maintenance and inspection at regular intervals. It is recommended to perform maintenance and inspection at intervals of either a total number of tightening of 100,000 operations or one year, whichever comes first.

It is advisable to disassemble and adjust the air drill at regular intervals. To keep the performance and avoid an unexpected accident, it is advisable to ask a specialist to disassemble and adjust the air drill at regular intervals. Record and store the results of measurements taken with a C.S UNITEC torque meter as well as torque data after bolt tightening.

◆ Repair

⚠ WARNING

Unauthorized modification or repair can cause an accident. We don't take any responsibility for an accident or malfunction if the air drill is modified or repaired by the user himself. The repair, disassembly, and adjustment must be left to your local C.S UNITEC dealer.

◆ C.S UNITEC Offices

For any additional information required, please refer to your local C.S UNITEC dealer of the following C.S UNITEC offices:



22 Harbor Ave
Norwalk, CT 06850
Tel: (800)-700-5919
Fax: (203)-853-9921
www.csunitec.com